



BISON Innovative Products

Get CEU Credits, Details, & Specifications online at www.bisonip.com

701 Osage Street, Unit 120, Denver, CO 80204 USA
Phone 303.892.0400 Toll Free 800.333.4234 Fax 303.825.5988
EMail info@bisonip.com Web www.bisonip.com

VERSADJUST
Adjustable Pedestals

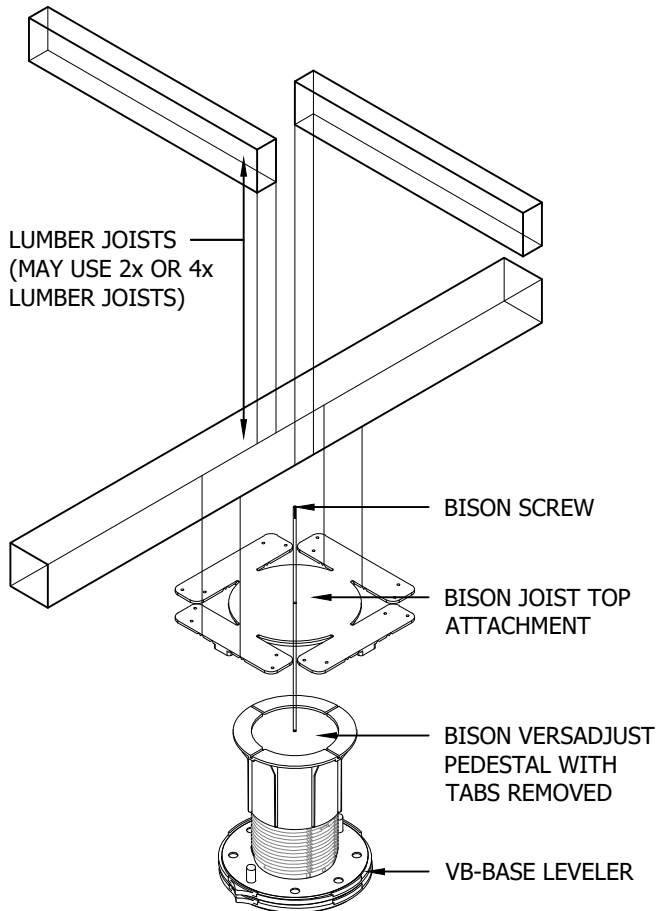

1. REMOVE TABS FROM BISON VERSADJUST PEDESTAL
2. PLACE BISON JOIST TOP ATTACHMENT ON TOP OF PEDESTAL
3. SCREW JOIST TOP ATTACHMENT INTO PEDESTAL USING BISON PROVIDED SCREW
4. PLACE LUMBER JOISTS (2x OR 4x) ON TOP OF BISON JOIST TOP
5. FOLD JOIST TOP FLAPS UP TO MEET LUMBER JOISTS
6. MECHANICALLY FASTEN FLAPS TO LUMBER JOISTS WITH #8 DECK SCREWS

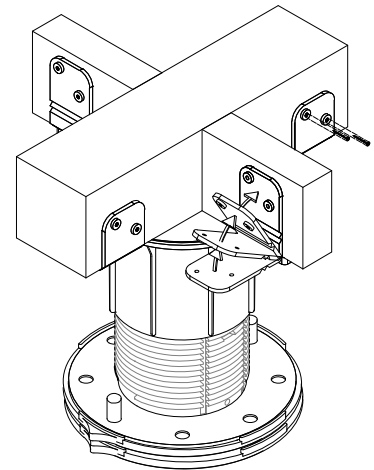

WHEN UTILIZING BISON JOIST TOPS FOR SUBSTRUCTURE FRAME CONSTRUCTION, THE CUSTOMER IS RESPONSIBLE FOR MAKING SURE ALL ELEMENTS OF THE SYSTEM HAVE BEEN DESIGNED IN ACCORDANCE WITH LOCAL CODE PROVISIONS AND ACCEPTED ENGINEERING PRACTICES FOR THE SPECIFIC JOB REQUIREMENTS OF THE PROJECT.

CONSIDERATIONS INCLUDE, BUT ARE NOT LIMITED TO:

1. PEDESTAL WEIGHT BEARING CAPACITY
2. POINT LOADING OF PEDESTALS
3. PERIMETER CONTAINMENT OF DECK
4. WEIGHT BEARING CAPACITY OF THE BUILDING AND ROOF SYSTEM
5. ANTICIPATED LIVE AND DEAD LOADS
6. PROPER JOIST SIZE AND SPAN FOR MATERIALS USED

GENERAL NOTES: APPLY TO ALL OF THE ABOVE PRODUCTS

1. INSTALLATION MUST BE COMPLETED IN ACCORDANCE WITH BISON INNOVATIVE PRODUCTS SPECIFICATIONS.
2. DRAWINGS NOT TO SCALE.
3. CONTRACTOR'S NOTE: FOR PRODUCT AND COMPANY INFORMATION VISIT www.BisonIP.com

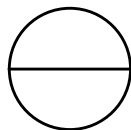

JOIST TOP

INSTALLATION INSTRUCTIONS